

REF. NO.	PART NO.	PART NAME	QTY.
1.	E20-9010	MAIN ROTOR BLADE.....	2
2.	E20-3000	(REF.) RETENTION STRAP ASSEMBLY.....	2
3.	E00-2523	BOLT AN5-32A 5/16 X 3-1/4.....	10
	E00-3500	NUT AN365-524A 5/16-24 FIBERLOCK.....	10
	E00-4501	WASHER AN960-516 5/16 REGULAR.....	20
4.	E00-2522	BOLT AN5-30A 5/16 X 3.....	4
	E00-3500	NUT AN365-524A 5/16-24 FIBERLOCK.....	4
	E00-4501	WASHER AN960-516 5/16 REGULAR.....	8
5.	E20-3141	WOOD END PLUG (MAKES 2).....	2
6.	E00-4900	SCREW #4 X 1/2 WOOD.....	20
	E00-4901	SCREW #4 X 3/4 WOOD.....	8
7.	E20-3151	WOOD END PLUG (MAKES 2).....	2
8.	E20-3170	TIP WEIGHT (MAKES 2).....	2
9.	E00-2404	SCREW 1/4-28 7/8" CSK.....	4
	E00-3410	NUT 1/4 THIN LOCK ALL METAL.....	4
10.	E20-7101	(REF.) DOUBLER FIBERGLASS, UPPER.....	2
11.	E20-3131	(REF.) WOOD FILLER BLOCK, UPPER.....	2
12.	E20-7111	(REF.) DOUBLER FIBERGLASS, LOWER.....	2
13.	E20-3121	(REF.) WOOD FILLER BLOCK, LOWER.....	2

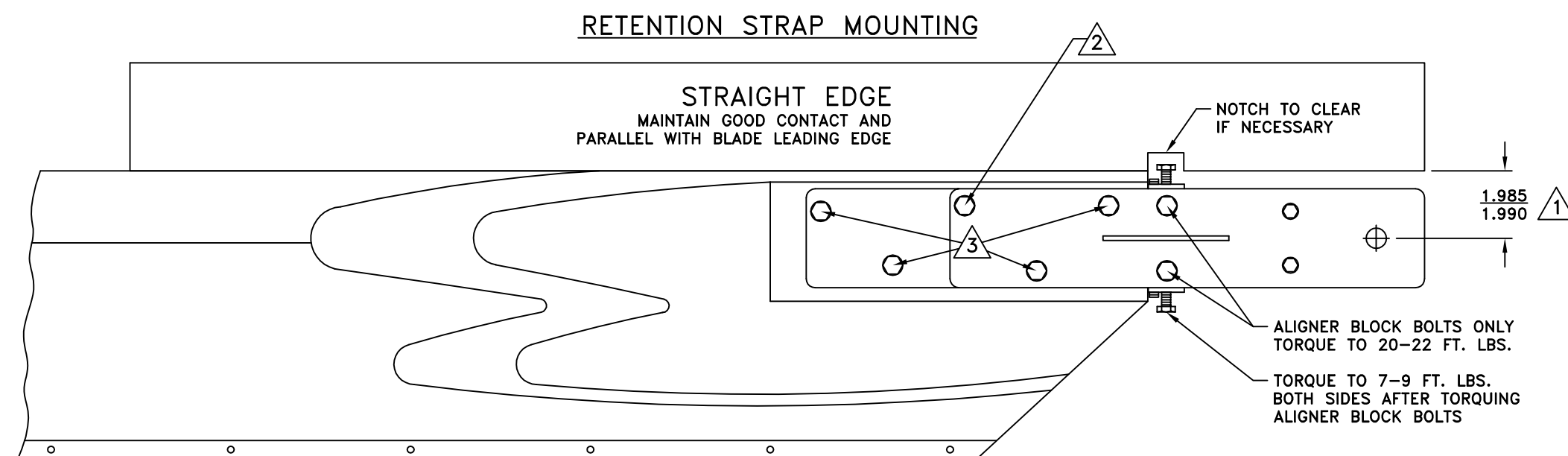
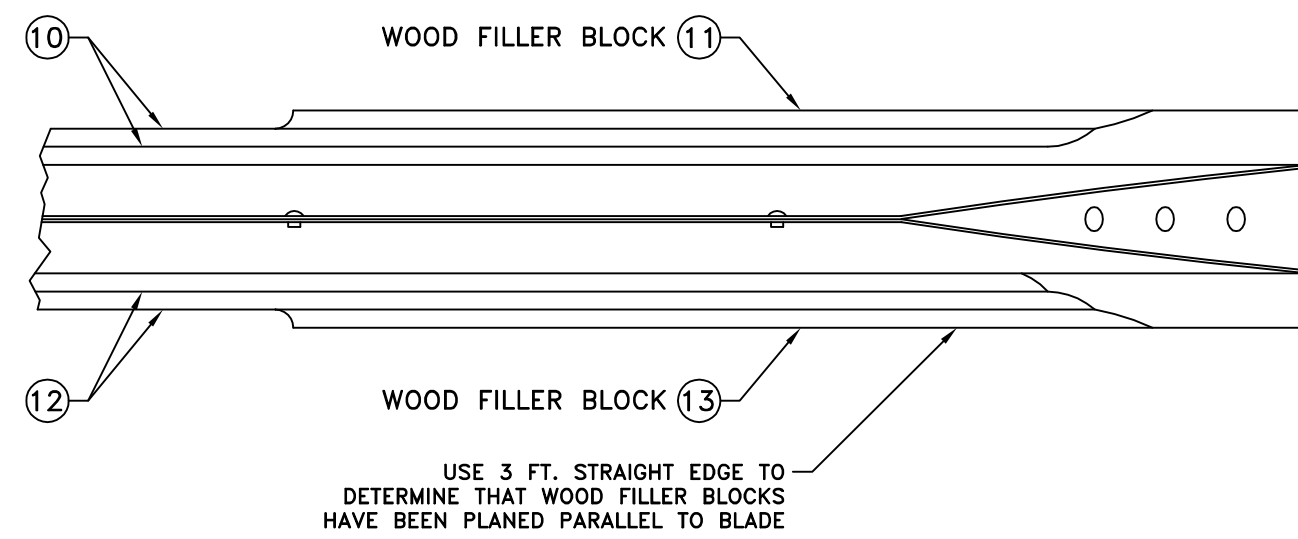

- NOTES:
- ① WHEN MAKING THIS MEASUREMENT, ALL ITEMS MUST BE LEVEL: BLADE, STRAIGHT EDGE, DIAL CALIPER.
  - ② PIVOT STRAPS ON THIS BOLT TO GET 1.985-1.990 DIMENSION.
  - ③ AFTER FINDING LOCATION, PASS 5/16 REAMER OR DRILL THROUGH REMAINING HOLES TO ENSURE EASY BOLT FIT.
  - ④ USE A THIN COAT OF 3M STRUCTURAL ADHESIVE BETWEEN STRAP AND WOOD FILLER BLOCK.

ROTORWAY HELICOPTER MANUFACTURING CO CHANDLER, ARIZONA			
SCALE: NONE	APPROVED BY:	DRAWN BY: WAR	
DATE: 1-24-08		REVISED:	
<b>MAIN ROTOR BLADES</b>			
MODEL: A600	DRAWING NUMBER: E20-2000	REV: A	