

REF. NO.	PART NO.	PART NAME	QTY.
1.	E25-6102	FUEL TANK, PILOT/LEFT.....	1
	E25-6112	FUEL TANK, PASSENGER/RIGHT.....	1
2.	E00-2301	BOLT 3/16 X 5/8.....	8
	E00-3301	NUT AN365-1032A 3/16 FIBERLOCK.....	8
	E00-4301	WASHER AN960-103 3/16 REGULAR.....	16
3.	E25-3110	CLAMP (MAKE FROM .063 STRAP).....	4
4.	E25-1400	RUBBER STRAP (4' LENGTHS SUPPLIED)....	4
5.	E00-2420	EYE BOLT AN43B-11A (1/4 X 1-1/8)....	2
	E00-3402	NUT AN365-428A 1/4-28 FIBERLOCK.....	2
	E00-4401	WASHER AN960-416 1/4 REGULAR.....	2
6.	E25-3100	FUEL TANK STRAP .063 X 3/4.....	1
7.	E12-3601	FUEL TANK BKT, PILOT (ON AIRFRAME).....	1
	E12-3611	FUEL TANK BKT, PASS. (ON AIRFRAME)....	1
8.	E00-2300	BOLT 3/16 X 1/2.....	6
	E00-3301	NUT AN365-1032A 3/16 FIBERLOCK.....	6
	E00-4301	WASHER AN960-103 3/16 REGULAR.....	12
9.	E24-9830	HEAT SHIELD, PILOT (FROM E24-9780)....	1
	E24-9831	HEAT SHIELD, PASS. (FROM E24-9780)....	1
10.	E00-9114	7/8 CUSHION LOOP CLAMP.....	2
11.	E00-2532	5/16 x 5/8 12 POINT BOLT.....	12
12.	E24-9881	HEAT SHIELD BRACKET (.063 STRAP).....	2
13.	E00-9100	TIE WRAP.....	8
14.	E00-2330	BOLT AN3-14 3/16 X 1-1/2.....	3
	E00-4301	WASHER AN960-10 3/16 REGULAR.....	6
15.	E24-1251	SPRING.....	3
16.	E00-3303	3/16 CASTLE NUT.....	3
17.	E00-5000	COTTER PIN 1/16 X 3/4.....	3
18.	E24-9011	MUFFLER/TAIPIPE WELDMENT.....	1
19.	E24-3151	MUFFLER STRAP (1 MAKES 4).....	4
20.	E24-3100	MUFFLER MOUNT RUBBER (1 MAKES 2)....	2
21.	E00-4302	3/16 FENDER WASHER.....	8
22.	E00-2304	BOLT 3/16 X 7/8.....	4
23.	E00-2433	BOLT 1/4-20 X 3/4 DRILLED HD.....	1
	E00-4401	WASHER AN960-416 1/4 REGULAR.....	1
24.	E00-2447	BOLT 1/4-20 X 5/8 DRILLED HD.....	1
	E00-4401	WASHER AN960-416 1/4 REGULAR.....	1

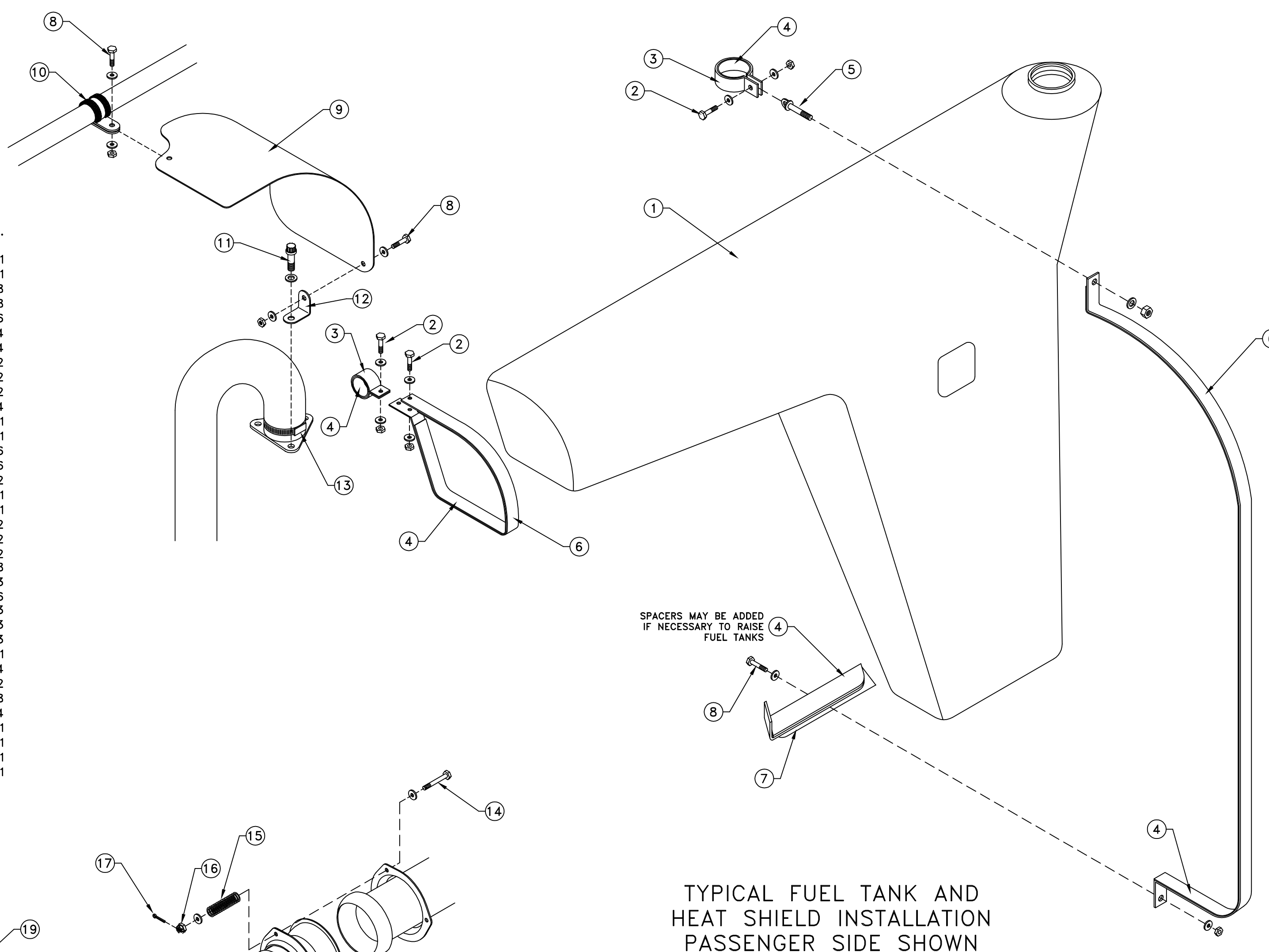

TYPICAL FUEL TANK AND HEAT SHIELD INSTALLATION PASSENGER SIDE SHOWN

ROTORWAY HELICOPTER MANUFACTURING CO CHANDLER, ARIZONA		
SCALE: NONE	APPROVED BY:	DRAWN BY: WAR
DATE: 1-22-08		REVISED: 3-20-17
<b>FUEL TANKS AND MUFFLER</b>		
MODEL: A600	DRAWING NUMBER: E25-2000	REV: A